

Air Disc Brake

Installation & Inspection Manual

**DMPBxxxx Series Piston Type Air Disc Brake
Installation and Inspection Manual**

▲ CAUTION : High **Compressed** spring is loaded inside of the Spring Brake. It is Very Important to read all the manuals and follow the instruction. Releasing piggyback or spring chamber forcefully without proper instruction may cause death, severe personal injury and/or property damage. If **Spring Brake is not caged**, mounting Nut and Clamp Nut should never be released. This may cause severe injury.



| Model | Type | Stroke | | Remarks |
|------------|------|--------|------|---------|
| | | inches | mm | |
| DMPB2024DI | 2024 | 2.5 | 63.5 | |
| DMPB2024DT | 2024 | 2.5 | 63.5 | |
| DMPB2424DI | 2424 | 2.5 | 63.5 | |
| DMPB2424DT | 2424 | 2.5 | 63.5 | |

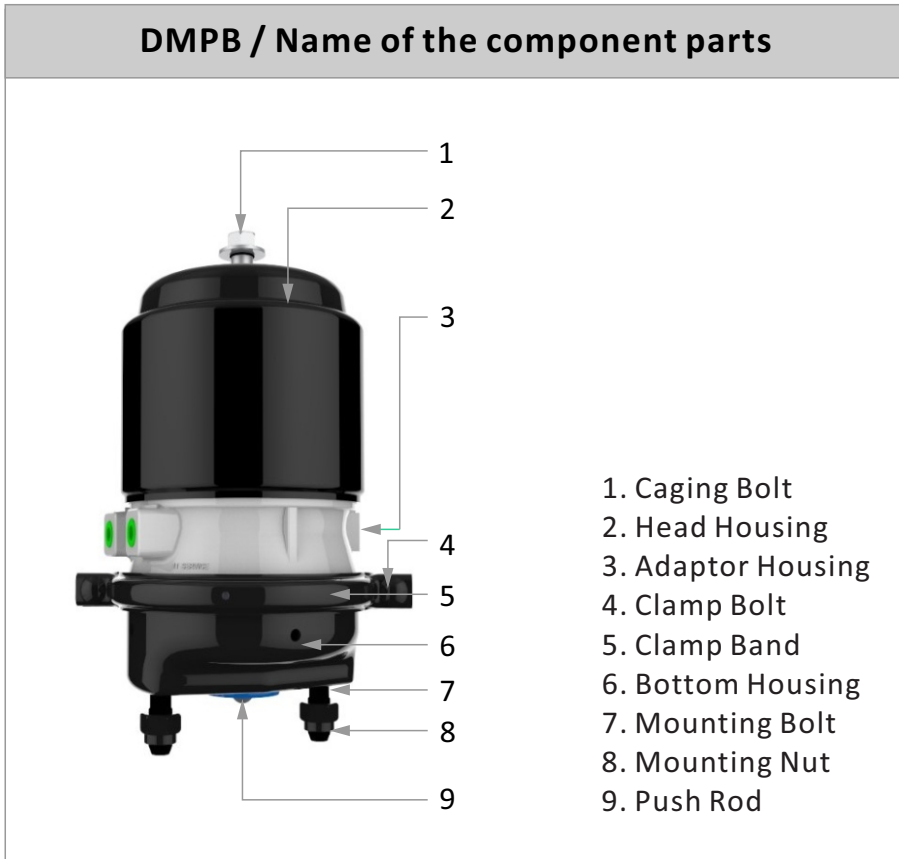

DMPBxxxx Series Piston Type Air Disc Brake Installation and Inspection Manual

Important Notification for Installation

Prior to installation, it is mandatory that the Spring Brake is caged.

If not caged, must be done before the installation.

To maximize the life of the Spring Brakes, we highly recommend you to follow the service manual when installing the product to your vehicle.

Air Disc Brake Chamber Removal Instruction

1. Always block wheels when working on brake to prevent vehicle rollaway.
2. After removing the parking brake, apply vehicle or shop pressure **6.2 ~ 8.3 bar** (90~120psi/620~830 kPa minimum) to emergency parking brake.
Maintain vehicle or shop air pressure, unscrew the caging nut counterclockwise from the side of the chamber housing using $\frac{3}{4}$ inch (19mm) wrench.
Open the head cover and use caging bolt to cage the spring brake.
If air leaks from the spring brake, you can manually cage the spring brake by using the caging bolt.
Slight loose fit between the yoke pin and slack adjuster is sufficient.
3. Activate the parking brake on the vehicle to exhaust all the air from inside of the spring brake.
4. Follow the manufacturer's instruction precisely, using spanner wrench, release the air hose and the connector from the chamber.
Marking before the separation to ensure the location of the air line and connector is highly recommended.
5. Using a 24mm (15/16 inch) socket wrench, unscrew the mounting nut (B) counterclockwise and cautiously remove the old chamber.

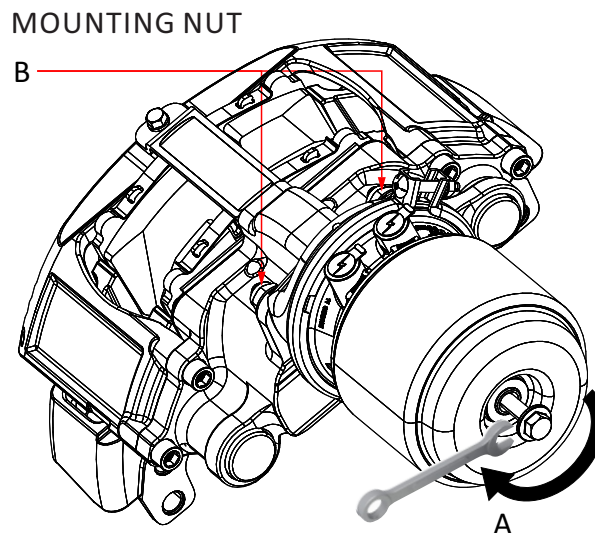

Installation of Air Disc Brake Chamber

▲ CAUTION: Before installing new air disc brake chamber, sealing surface must be cleaned. Using grease recommended by manufacturer, apply it to the cup inside of the LEVER flange surface (A) should be free from damage and impurities. Seal and Pushrod area must be in dry condition and free from impurities.

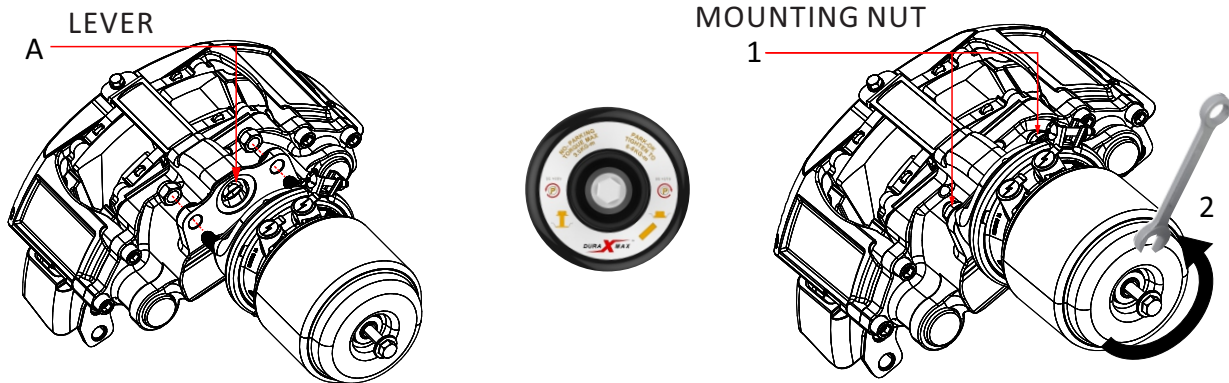

1. Prior to spring brake chamber installation, ensure that spring brake is completely caged (power spring caged), and the service brake pushrod is fully retracted to zero stroke position.
2. Install the spring brake chamber to caliper bracket and using 24mm(15/16 inch) mounting nut (1) socket wrench , screw the mounting nut clockwise.
Recommended torque is **18~21kgf.m**(133~155 lbt.ft).
3. Using Loctite glue or Teflon tape, tighten the chamber fitting at **3.6kgf.m**(25lbf.ft) torque.
Connect the correct air hose to each position.
Air hose needs to be free from entangling and interference at all time.
4. After charging the air tank to **6.2~8.3 bar**(90~120 psi / 620~ 830 kPa), release the parking brake (parking level off), I,e, charge the spring chamber, turn caging volt to clockwise to **torque at 6~8Kgf.m** (44~58 lbf.ft)

Installation Inspection

1. After charging the air tank to 6.2~8.3 bar (90~120 psi/620 ~830kPa), release the parking brake. Using soapy water (**NEVER ANY TYPE OF OIL**) inspect air leak from airline and fitting and also from service part airline and fitting during foot brake operation.
2. Follow your vehicle manufacturer's recommended manual for brake adjustment.

SAFE SCRAP old Spring Brake

1. All retired spring brake chamber must be safely disarmed before they are disposed of to prevent serious personal injury and property damage from accidental sudden release of the high energy spring.
2. To dispose the spring chamber, place it in the steel container and close it.
Use gas torch to cut through the head housing and cut the actuator spring.